

TOP (PLAN) VIEW

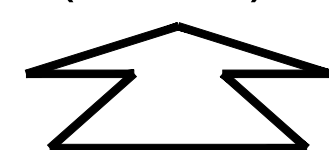

DIRECTION OF VEHICLE ATTACK

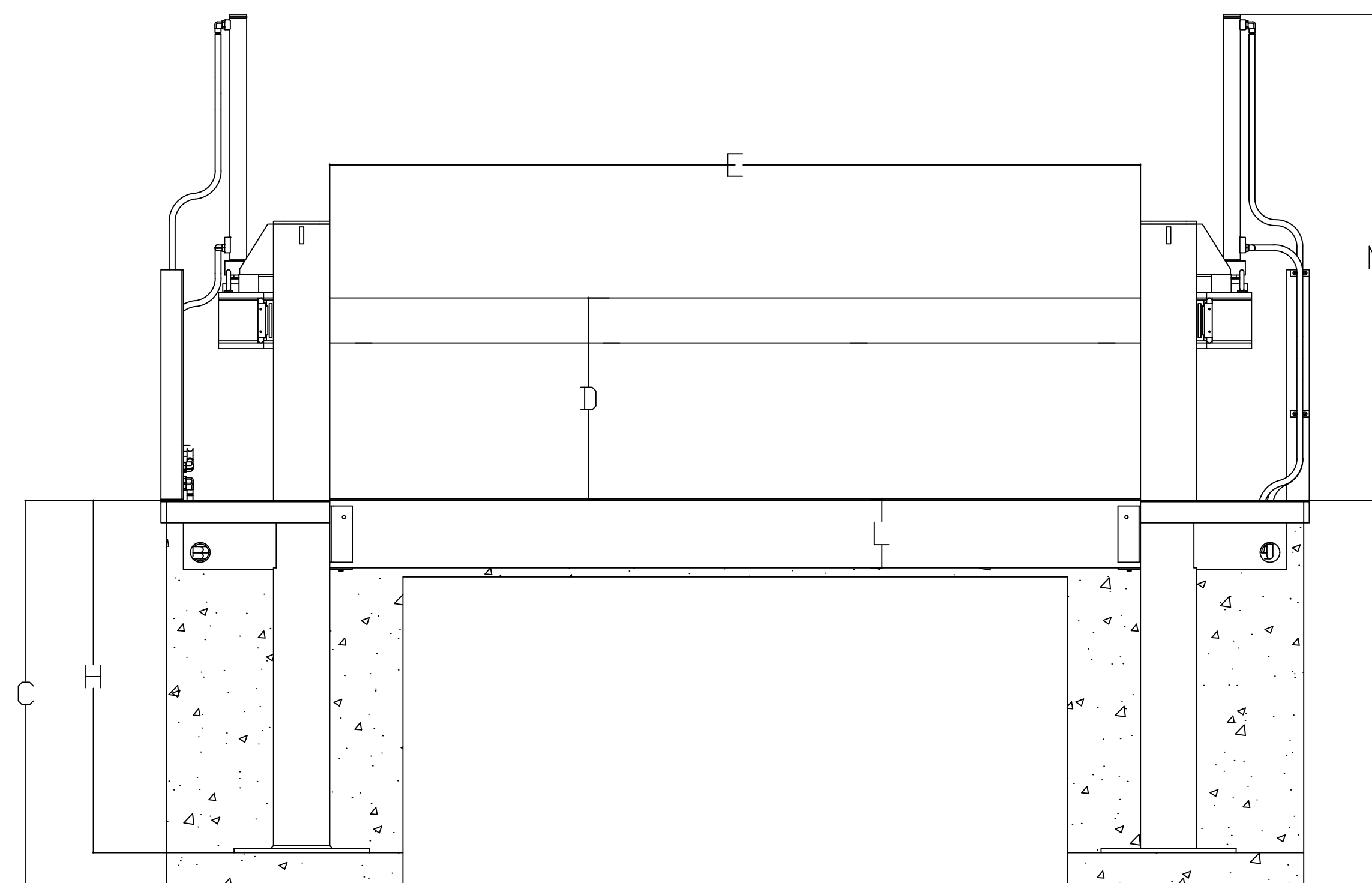

FRONT (ELEVATION) VIEW

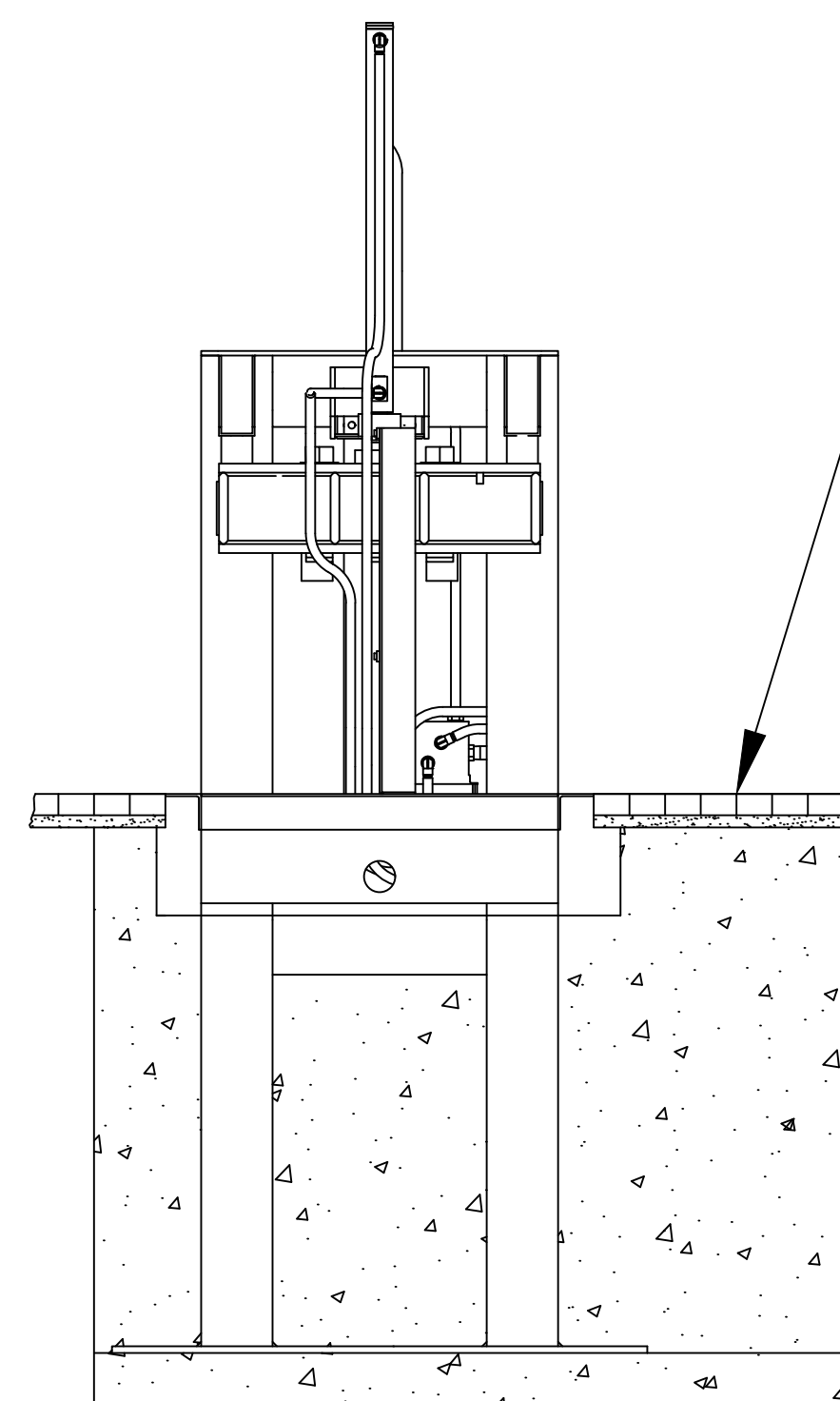

SIDE (ELEVATION) VIEW

CUSTOMER DEFINED OPTIONAL
ROADWAY SURFACE TREATMENT
(COMPLIES WITH CRASH RATING
USING ANY PAVERS, ASPHALT, ETC.)

	Dimension	A	B	C	D	E	F	G	H	J	K	L	M
12' foot	Inch	202.0	84.0	68.63	36.0	144.0	24.5	37.0	62.63	42.0	40.0	12.0	86.4
	mm	5131	2134	1743	914	3658	622	940	1591	1067	1016	305	2194
OTHER CLEAR OPENING WIDTHS ARE AVAILABLE													
24' foot	Inch	346.0	84.0	68.63	36.0	288.0	24.5	37.0	62.63	42.0	40.0	12.0	86.4
	mm	8788	2134	1743	914	7315	622	940	1591	1067	1016	305	2194

Notes:

1. The Patriot is K12 crash test certified by the U.S. Department of State (DOS) in 12 foot opening.
2. The Patriot is M50/P1 crash test certified according to ASTM F2656-07 in 24 foot opening.
3. All openings between 12 and 24' are engineered to meet ASTM F2656-07.
4. Black paint is standard. Custom specified paint colors are available.
5. Heaters are available for cold weather applications.
6. Hydraulic Power Unit (HPU) and Operator Control Panels are not shown.
7. Weather-proof HPU enclosure is standard.
8. Traffic signal lights, warning lights, vehicle detector loops, and other accessories are available.
9. Side columns can be hidden behind themed architectural walls, fences or facades.
10. Up to 4 inches (10mm) of decorative roadway material can be used around barrier.
11. Construction and installation by others, such as concrete foundation, rebar, roadway surface, conduit, wiring and hydraulic hoses.

Unless Noted Otherwise				PROPRIETARY INFORMATION	
.x	Decimal	± .040	DO NOT SCALE	This drawing is the proprietary property of AMERISTAR, Tulsa, OK and must not be duplicated or used in whole or in part for the making of drawings, prints or parts to the detriment of, or harm to, the owner. In accepting this drawing, the recipient agrees to keep the information contained confidential.	
.xx	Decimal	± .030	OFF DRAWING		
.xxx	Decimal	± .020			
.xxxx	Decimal	± .010	Angular ± 0.5°		
REVISION HISTORY					
REV	ECN	AUTHOR	DATE	DESCRIPTION	
A		INIT	DATE	Initial Release	
				TITLE: PATRIOT ARCHITECTURE GENERAL	
				DATE: .	SHEET: 1 of 1
				DRN BY: .	REV: A
				DRAWING NO: PATRIOT ARCHITECTURE GENERAL	



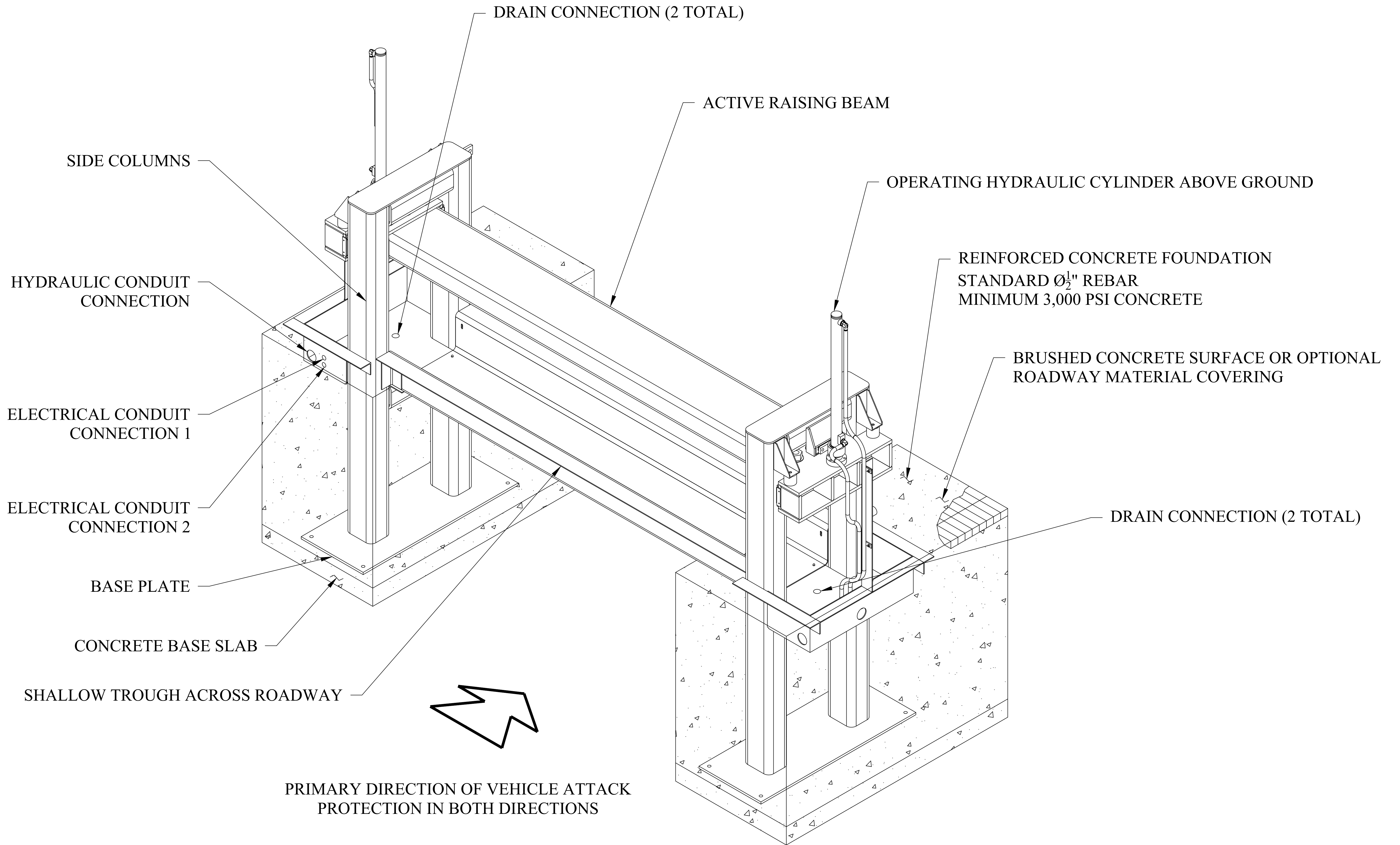

Unless Noted Otherwise				PROPRIETARY INFORMATION	
.x	Decimal	± .040	DO NOT SCALE	This drawing is the proprietary property of AMERISTAR, Tulsa, OK and must not be duplicated or used in whole or in part for the making of drawings, prints or parts to the detriment of, or harm to, the owner. In accepting this drawing, the recipient agrees to keep the information contained confidential.	
.xx	Decimal	± .030	OFF DRAWING		
.xxx	Decimal	± .020			
.xxxx	Decimal	± .010	Angular ± 0.5°		
REVISION HISTORY					
REV	ECN	AUTHOR	DATE	DESCRIPTION	
A		INIT	DATE	Initial Release	
				TITLE: PATRIOT ARCHITECTURE GENERAL	
				DATE: .	SHEET: 1 of 1
				DRN BY: .	REV: A
				DRAWING NO: PATRIOT ARCHITECTURE GENERAL	

1555 N. Mingo
Tulsa, OK 74116
1-888-333-3422
www.ameristarfence.com