

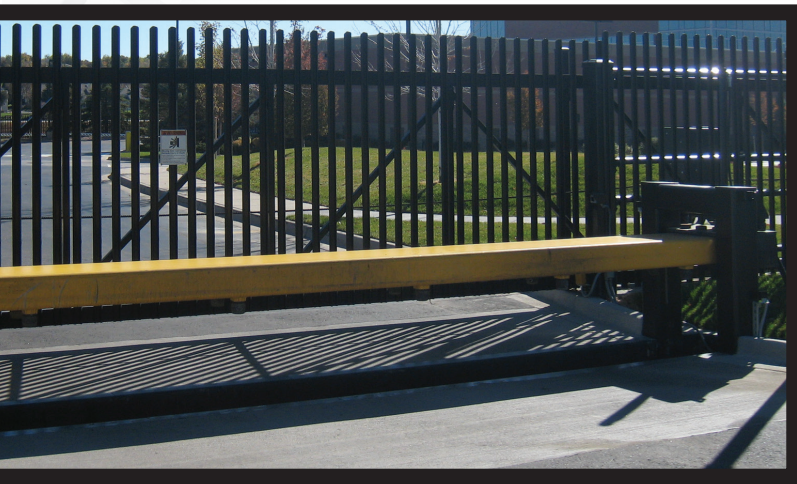

PATRIOT[™]

ANTI-RAM CERTIFIED CRASH BEAM



Patriot *rising beam barriers* offer the highest level of protection for entry control access. Traversing a maximum distance of 24', the Patriot beam barrier *blocks entire roadways from any potential threat or unauthorized vehicle.*

K12

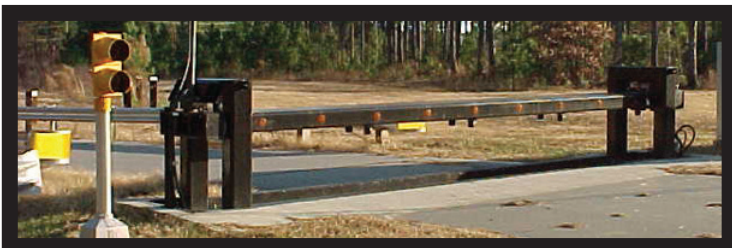
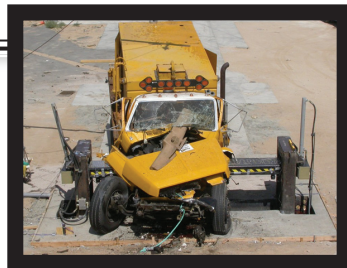
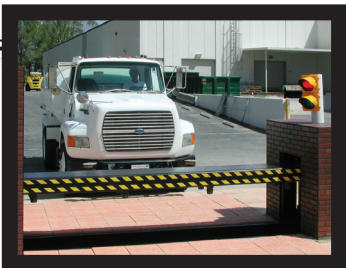

SECURITY ADVANTAGES

- ▶ *Installing the rising beam barrier within close proximity to an entry point enables the Patriot to work in tandem with a gate system to control vehicular traffic*
- ▶ *The Patriot crash beams' primary excavation is outside the roadway opening, allowing minimal excavation across entry, thus avoiding underground utilities or obstructions*
- ▶ *Deployment rate of only one second when EFO (emergency fast operation) control is added to this system*



PATRIOT™



AMERISTAR®
SECURITY PRODUCTS



ATG ACCESS

ANTI-RAM CERTIFIED CRASH BEAM

CRASH BEAM

STANDARD FEATURES

- ▶ **Standard Openings / 12', 16', 20' & 24'**
(available in custom sizes in 2' increments up to 24')
- ▶ **Barrier-Down Position Sensor**
- ▶ **Painted Finish**
- ▶ **Weather Proof HPU Enclosure**
- ▶ **HMI PLC & Programming**
- ▶ **2 HP Hydraulic Power Unit**
- ▶ **208-240 VAC / 60 HZ / 3-Phase**
- ▶ **Manual Hand Pump**

OPTIONAL FEATURES

- ▶ **Main Operator Control Panel**
- ▶ **Remote Operator Control Panel**
- ▶ **Barrier-Up Position Sensor**
- ▶ **Hydraulic Oil Heater / Cooler**
- ▶ **Emergency Fast Operation (EFO)**
- ▶ **Dual Channel Vehicle Detector Module**
- ▶ **Traffic Light Signals**
- ▶ **Custom Painted Finish**
- ▶ **Battery Backup**
- ▶ **Touch Screen Controls**
- ▶ **Radio Controls**
- ▶ **Wrong Way Detection**
- ▶ **Over-Speed Detection**
- ▶ **Integrated Traffic Arm or Sliding Gate**
- ▶ **5 HP Hydraulic Power Unit**

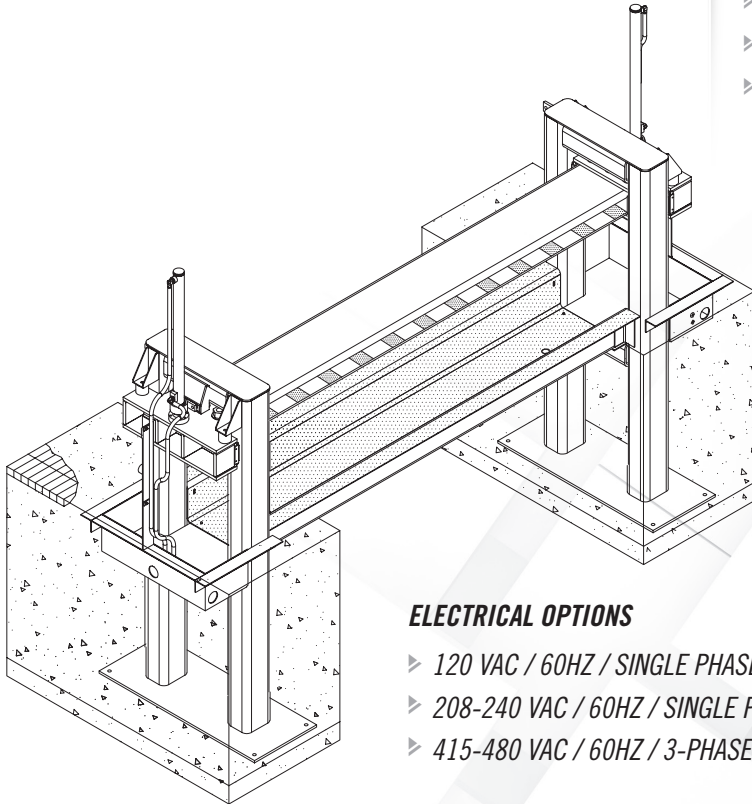

ELECTRICAL OPTIONS

- ▶ **120 VAC / 60HZ / SINGLE PHASE**
- ▶ **208-240 VAC / 60HZ / SINGLE PHASE**
- ▶ **415-480 VAC / 60HZ / 3-PHASE**

#9832 | REVISED 10/2019



SECURITY PRODUCTS

TO PLACE YOUR ORDER CALL 866-467-2773

VISIT AMERISTARSECURITY.COM